

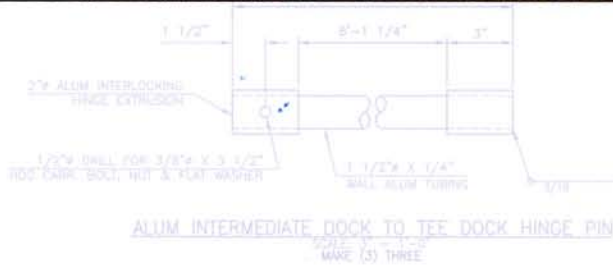

HALLSTEN
CORPORATION
 INDUSTRIAL • MARINE • ENVIRONMENTAL



We offer **MARINE SOLUTIONS**

NOTE:

- 1) TOP OF ALUMINUM DECKING IS RUBBED AND SANDBLASTED TO A COMMERCIAL FINISH FOR A NON-SKID SURFACE.
- 2) ALUMINUM BOND TO BE SANDBLASTED FOR A NON-SLARE FINISH.

ALL STEEL PARTS TO BE HOT-DIP GALVANIZED

Aluminum Boat Docks

MUNICIPAL WATER DISTRICT

8' X 20' TEE DOCK,
 SECTIONS &
 DETAILS



1-(800)-473-7440

Date: 12 MAY 05

Manager: R. KUHN

Drawn By: D. LERLY

Sheet No: 10488

REVISIONS

ALUMINUM

Mooring Cleats Bolted Through Dock Frame



Heavy Polyethylene Tubes w/EPS Foam



Aluminum Decking Ribbed & Sandblasted

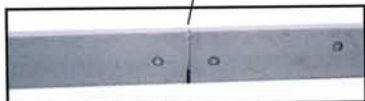
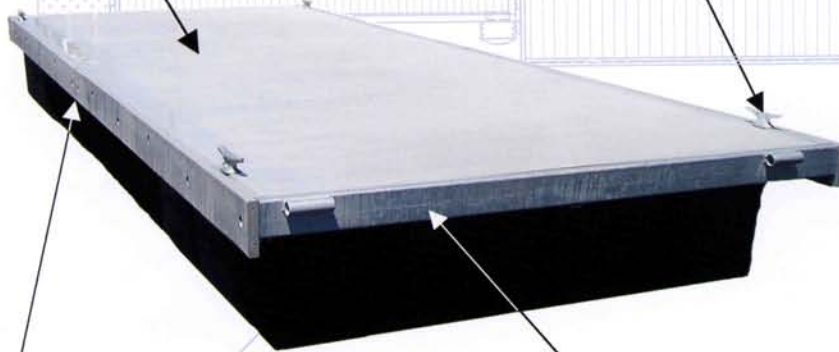

Solid Polyethylene Fender/Bumper w/no Wood Content



Optional Heavy Duty Vinyl Interlocking Fender/Bumper



Galvanized Steel End Tube w/Hinges, Bolted to Frame



Aluminum Frame Tub Attaching Track

OVER 30 YEARS OF QUALITY, INTEGRITY AND INGENUITY

For over thirty years Hallsten Corporation has designed and fabricated metal structure for industry. Through this time Hallsten has developed specialized aluminum extrusions and assembly techniques that have resulted in numerous patents. Our unique aluminum extrusions, when combined with structural polymers and stainless components, represent a significant advance in versatility and quality of structures for Industrial, Marine and Environmental applications.

BOAT DOCKS

Flotation

Attachment Lugs Molded into Polyethylene Tubs

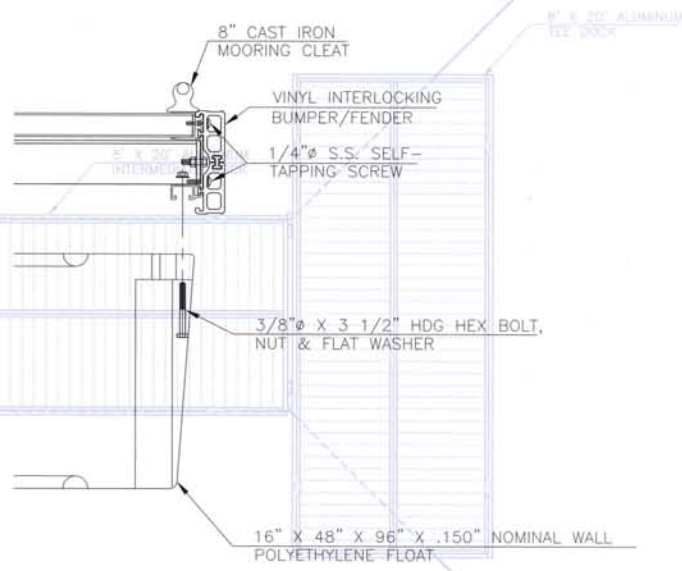
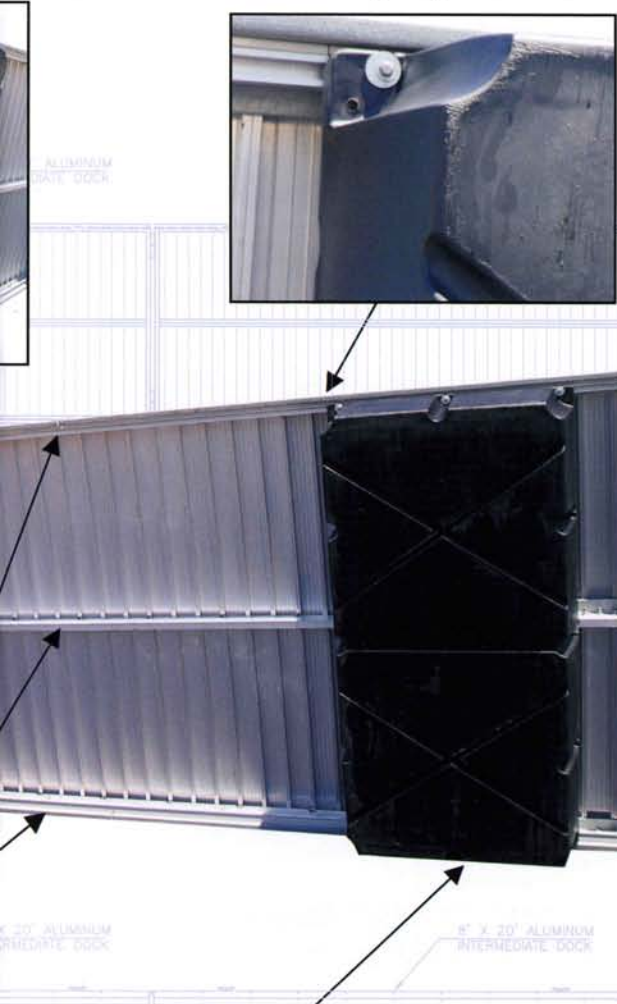

Size, Location & Quantity of Flotation Tubs as Determined by Live Load

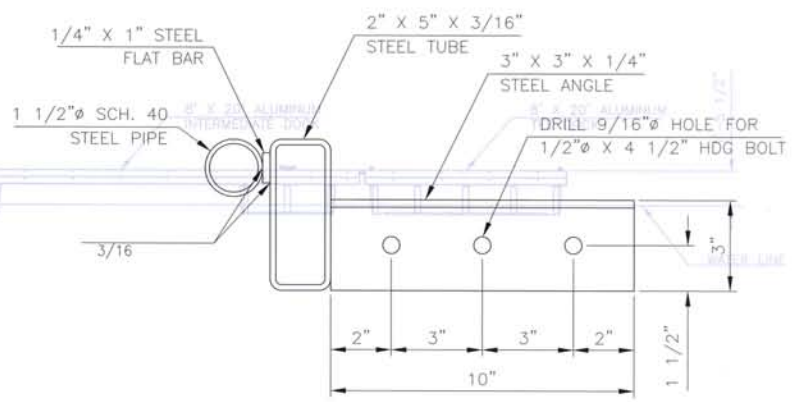

HALLSTEN ALUMINUM BOAT DOCKS

- LONG LIFE - Aluminum assembled without welds.
- SAFETY - Decking is ribbed and sandblasted.
- VERSATILITY - Dock modules connected end to end or side to side for double width.

The most innovative and cost effective marina system.



HALLSTEN CORPORATION
INDUSTRIAL • MARINE • ENVIRONMENTAL

ALUMINUM-DECKED TUB-FLOATATION DOCK SPECIFICATIONS

GENERAL REQUIREMENTS

These specifications are for a fully CAD designed and engineered Aluminum Decked Tub Flotation dock system and are the minimum standards for design and fabrication. The dock system shall be designed and manufactured by HALLSTEN CORPORATION., P O Box 41036, Sacramento, CA 95841. Phone: ((916) 331-7211, FAX: (916) 331-7223.

ENGINEERING

Dock flotation shall be designed to support the dead weight of the complete dock, including any permanently attached accessories, plus an additional live load of 20 pounds per square foot over the entire dock area. Flotation material shall be distributed as widely as possible under the dock for maximum stability. Minimum freeboard under combined dead and live load shall not be less than 8 inches. Freeboard under dead load only shall be between 16 and 22 inches.

Factors of Safety

The deck and structural components shall be designed with minimum safety factors on working stresses, which conform to those specified in the American Association Design Manual specification for aluminum structures, as applicable.

Vertical Design Loads

The dock structure and deck shall include the dead weight of the dock components as well as a vertical distributed live load of 20 pounds per square foot of dock area. The deck and structural components shall also be designed to support the dead load plus a concentrated vertical live load of 400 pounds applied over a 6" x 6" area located anywhere on the deck surface. The distributed and concentrated live loads need not be applied simultaneously.

Horizontal Design Loads

The dock structure and deck shall be designed for a lateral load of 150 pounds per foot of length to account for wind and water currents.

Connections Between Dock Modules

Connecting hardware(hinges) and its attachments between any adjacent dock modules shall be designed to support a bending moment in the horizontal plane of 3000 foot-pounds.

MATERIALS DECKING

Decking shall be aluminum deck slat 6" wide by 1.61" deep produced from alloy 6061-T6 with ribbed non-skid surface. The deck slats shall interlocking top and bottom with rolled interlocks which causes the slats to act together when loaded. The ends of the deck slats interlock into the structural frame and are retained without welding. After installation, the decking shall give an AA-M44(course matte) finished to increase skid resistance, reduce glare, and give a uniform appearance.

Polyethylene Fender/Bumpers

Fenders shall be solid "Select Lumber" High Density Recycled Polyethylene lumber, 2" x 8" nominal measure. The material shall be Gray in color and contain ultraviolet stabilizers to resist weathering and surface degradation. The fender shall be countersunk and bolted to the dock sides on all exposed surfaces. The fender shall have no wood or wood product content.

Steel Bolts

Bolts shall be American standard regular with hexagonal heads and nuts, and shall be hot-dipped galvanized in accordance with ASTM A153.

Flotation Tubs

The buoyant units of the docks shall be polyethylene tubs having a wall thickness of .150 nominal. The tubs shall conform to ASTM D1248 and shall be manufactured in such a way as to be resistant to UV radiation from sunlight for 20 years. The tubs shall be roto-molded, complete, in one piece and completely filled with polystyrene foam. The foam shall be cast within the tub and produced with no voids. The foam shall have a minimum density, in place, of 0.9 pounds per cubic foot and a maximum density of 1.2 pounds per cubic foot. The tub shall be produced with structural ribs, top, bottom and sides and with heavy mounting flanges on sides and ends.

Connection of Tubs

The polyethylene tubs shall be connected to the Utility Mounting Track on the underside of the dock with 3/8" galvanized bolts through the mounting flanges on the tub sides and ends.

Mooring Cleats

Mooring cleats shall be installed on the dock where shown. The cleats shall have, as a minimum, the dimensions shown on the drawings, be fabricated steel, galvanized after fabrication, and shall be sufficient to withstand a static of 500 pounds in any direction, applied by a rope secured to the cleat.

FABRICATION & WORKMANSHIP

The quality of workmanship shall be equal to the best general practice in modern structural fabrication shops.

Experience

The fabricator must be able to furnish adequate evidence of a minimum of 5 years of ongoing successful experience in fabricating aluminum dock structures, and shows that all workmen employed in dock fabrication are properly experienced and skilled in the work they are called upon to perform.

Hallsten Corporation - We Offer Solutions.

TOLL FREE 1- (800)-473-7440

MAILING ADDRESS:

P.O. Box 41036, Sacramento, CA 95841
Tel. (916) 331-7211 • Fax: (916) 331-7223

Plant Address:

6944 34th Street, North Highlands, CA 95660

CONFIDENTIAL - TECHNICAL DOCUMENT

INDUSTRIAL • MARINE • E

P.O. Box 41036, Sacramento, CA 95841

TEL (916) 331-7211

© 2005

ALUM GANGWAY & DOCK

LAKE CASITAS, CA

© 2005